

# Design and Implementation of Solder Paste Dispensers Based on Linear Drive Systems (Desain dan Implementasi Dispenser Pasta Solder Berdasarkan Sistem Drive Linier)

Riky Tri Yunardi <sup>1)</sup>, Mohammad Zakky Zulfiar <sup>2)</sup>, Rr. Wanda Auruma Putri <sup>3)</sup>, Deny Arifianto <sup>4)</sup>

<sup>1,2,3,4)</sup> Department of Engineering, Universitas Airlangga Surabaya, Surabaya, Indonesia

<sup>1)</sup> \*rikytriyunardi@vokasi.unair.ac.id

**Abstract.** In the technology to create prototypes for electronic hardware is usually constructed using surface mount device printed circuit board (SMD PCB). In this paper introduces the design and implementation of low-cost electrical solder paste dispenser that supports the PCB solder process. The design consists of a nozzle and linear drive systems based on stepper motors operating with electric power to push the plunger down to drop the solder paste on the board. To test the performance of solder paste that has been designed verified by experiment. Solder paste dispenser design was tested using SMD resistor with the solder pads of different sizes for R0603, R0805, and R1206 on PCB. The results showed that the design of the prototype was able to put the pasta in various field pads between 0.54 mm<sup>2</sup>, 0.91 mm<sup>2</sup> and 1.44 mm<sup>2</sup> for standard solder pads with an error in the 2% - 5%. Based on the results, the device has been shown to potentially be used to attach electronic components to printed circuit boards.

**Keywords:** Solder Paste Dispenser; SMD; Printed Circuit Board; Linear Drive System.

**Abstrak.** Dalam teknologi untuk membuat prototipe untuk perangkat keras elektronik biasanya dibangun menggunakan permukaan mount perangkat papan sirkuit cetak (SMD PCB). Dalam makalah ini memperkenalkan desain dan implementasi dispenser pasta solder listrik murah yang mendukung proses solder PCB. Desainnya terdiri dari sistem nosel dan penggerak linier berdasarkan motor stepper yang beroperasi dengan daya listrik untuk mendorong plunger ke bawah untuk menjatuhkan pasta solder ke papan. Untuk menguji kinerja pasta solder yang telah dirancang diverifikasi oleh percobaan. Desain dispenser pasta solder diuji menggunakan SMD resistor dengan bantalan solder dengan ukuran berbeda untuk R0603, R0805, dan R1206 pada PCB. Hasil penelitian menunjukkan bahwa desain prototipe mampu menempatkan pasta di berbagai bidang bantalan antara 0,54 mm<sup>2</sup>, 0,91 mm<sup>2</sup> dan 1,44 mm<sup>2</sup> untuk bantalan solder standar dengan kesalahan 2% - 5%. Berdasarkan hasil, perangkat telah terbukti berpotensi digunakan untuk memasang komponen elektronik ke papan sirkuit cetak.

**Kata Kunci:** Dispenser Pasta Solder; SMD; Papan Sirkuit Terc-

Etak; Sistem Penggerak Linier.

## INTRODUCTION

The development of industrial technology is rapidly increasing, sophisticated and modern encourage people to meet their needs quickly, accurately, and efficiently. One of the technologies developed at this time is in the field of electronics. Many manufacturers make different kinds of electronic equipment to assist and facilitate the work of human beings to make it easier and more efficient [1, 2]. One type of electronic equipment made is a solder paste dispenser with various features it has. Solder paste dispenser is the most commonly used to connect all the electronic components to the board. Solder paste dispenser is a device used to connect electronic components on the surface of the PCB (Printed Circuit Board) using solder paste system. Currently, the solder paste method available is limited to stencil solder paste dispenser and manual nozzle methods may be highly inaccurate and time-consuming [3–5]. In general, the solder paste dispenser still use pneumatic. The solder paste system is driven by air pressure through the nozzle system [6]. The pneumatic dispensers commercially are available, commonly used in the manufacturing industry and expensive. Following from previous research in pneumatic solder paste dispenser has a problem such as a pressure drive system affected by heat, humidity, air pressure fluctuations, changes in viscosity. It can weaken the ability of the dispenser to eject the liquid solder paste on the surface of the PCB (Printed Circuit Board), particularly in SMD (Surface Mount Device) [7].

To solve the problem, some researchers have suggested the use of electrical solder paste dispenser [8, 9]. Gu *et al* developed a solder paste dispenser based on the piezoelectric stack [10]. In this paper introduces the design and implementation of low-cost electrical solder paste dispenser that supports the PCB soldering process. The design consists of a nozzle and linear drive systems based on stepper motors op-

erating with electric power to push the plunger down to drop the solder paste on the board.

The purpose of this research is to design and implementation of low-cost electrical solder paste dispenser that supports the PCB soldering process. The contribution of this design is categorized as easy to assemble the solder paste dispenser with a nozzle and linear drive systems based on stepper motor operating by electric power [11]. This solder paste dispenser design is basically a nozzle filled with pasta and stepper motors to push the plunger down. The drive linear system is used to push the plunger along the inside of the barrel to eject and drop the solder paste. Further to examine the performance, the solder paste dispenser of the design has been verified by experiments using SMD resistor solder pads of different sizes for R0603, R0805, and R1206 on PCB [12].

**DESIGN OF SOLDER PASTE DISPENSER**

Solder paste dispenser has been designed and controlled by the stepper motor to drive the plunger. As shown in Figure 1, the device consists of a prototype accommodates DC stepping motor, motor driver system and aluminum plunger bar is placed in a tube. A barrel tube dispenser made of clear plastic with a 20mm diameter containing solder paste liquid maximum is 30ml.

In this design is shown in Figure 2, the stepper motor coupled with screw rod are made of stainless steel and a plunger with a rubber seal at 100mm. The encoder coupling 10mm / 12mm is used for holding the stepper motor shaft and screw rod. The screw rod is used as the base of a mechanism to provide the linear drive for the plunger to be moved by the actuator. The pitch of the screw is 1mm and the diameter rod is 8mm.

*Operating Mode Algorithm*

Steps the development of algorithms for building software programs is using application set of instructions that control the operating mode of solder paste dispenser system. Software used is the C++ programming. This mode of operation is made to control the system with four switches on the keypad and liquid crystal display. Program to be made in this system includes a GUI (Graphic User Interface) in the form of push button and LCD.

In the push button function as the selection of the desired movement of the stepper motor, while the LCD is used to display of the pad types and micro stepping of the motor movement by the stepper motor driver. Motor speed is set by taking the paste that was dropped on the board. In program mode, the program requires input from the user to select the size of the pad consists of R0603, R0805 and R1206. The input entered with the keypad switches, LCD will display a selection of the size of the pad on the screen. Figure 3 shows a flowchart of the algorithm operating mode for the dispenser system.

[Figure 1 about here.]

[Figure 2 about here.]

The stepper motor moves in discrete steps, one way to control a step motor using micro stepping. Micro stepping performed by applying a PWM (pulse-width modulation) to control the current to the motor windings [13]. Micro stepping consists of three selectors (20, 30, and 70), which resulted in three modes of motion resolution. Resolution motion function correctly if the system can be used to push the plunger to drop the paste on the three different sizes of pad.

In this study, solder paste dispenser is controlled by pressing a button to select the size in accordance with the desired pads and pad type selection will be displayed on the LCD. UP and DOWN buttons are used to change the type of pad displayed on the screen. After completion of the pad type selected, followed by pressing the ENTER so that the dispenser system will be ready for operation. At the time ENTER button pressed, a stepper motor of the dispenser cannot be operated before the signal of the ON/OFF button is pressed. The ON/OFF button will only work if the pad size is selected by pressing the ENTER. RESET button is used to restore the system to the beginning condition.

[Figure 3 about here.]

*Electrical Wiring Diagram*

Electrical wiring diagram in this study are shown in Figure 4, the main controller is a push button to signal the ON/OFF as a key driver of solder paste dispenser. DC stepper motor driver is used as a stepper controller as a linear drive system. In addition, a driver using A4988 module to control bipolar stepper motor which has a production capacity of up to 35 V and ± 2 A [14]. IC 7805 is used to stepping down +12V supply voltage to +5V to powering the electrical components shown in Figure 5 and Figure 6.

[Figure 4 about here.]

[Figure 5 about here.]

[Figure 6 about here.]

*LCD and Push Buttons Interfacing*

The LCD monitor display and push buttons that is used as an interface between the user and the device. A 16x2 LCD display serves as a viewer the selection of the three sizes of the pad that chosen by the user using buttons as shown in Figure 7. LCD is connected to pin 2, pin 3, and pin 9 to pin 12. Input button consists of four buttons to navigate were

interfaced with four pins of the port of the microcontroller is connected to pin A.1 to A4. The navigation key consists of a key ENTER, UP, DOWN and RESET. Push button to provide a signal ON/OFF connected to pin A.0. Stepper motor driver is connected to pin 3 to pin 7 to move the linear drive for the plunger.

[Figure 7 about here.]

#### IMPLEMENTATION OF SOLDER PASTE DISPENSER

Figure 8 shows a prototype of a solder paste dispenser designed. The implementation of the system consists of a simulation when pushing the plunger to drop the solder paste on the board and measure the size of each droplet to verify the correctness of the system. User chooses the pad size type through an interface. The pad size determination based on a comparison of the size of the target size SMD resistor on the board. Table 1 summarizes the results of the droplet size tests of paste.

[Figure 8 about here.]

[Figure 9 about here.]

[Table 1 about here.]

#### RESULTS AND DISCUSSION

In order to evaluate the performance of the presented dispenser system to dropping of solder paste on the board to test the effectiveness of the linear drive to push the plunger. The tests carried out on each pad size chosen by the user. This test will know the accuracy of the prototype, based on R0603, R0805, and R1206 SMD type of pad will give results. Every 10 times to repeat shows that solder paste droplet diameter decreases hole nozzle diameter decreases leading to errors. From the measurement, results can be seen that in setting 0.54 mm<sup>2</sup>, readings of 10 times the average of 0.57 mm<sup>2</sup>, the relative error of between 5%. For the pad size of 0.91 mm<sup>2</sup> the percentage reaches 3% with an average size is 0.89 mm<sup>2</sup>. Moreover, in 1.44 mm<sup>2</sup>, an average of 1.42 mm<sup>2</sup>, the relative error of between 2%. The percentage of these errors will be reduced if the nozzle hole during the process is not clogged by dried pasta.

#### Conclusion

This paper discusses the solder paste dispenser simple and inexpensive design using a linear drive system. By using stepper motor coupled with a screw rod to provide linear movement of the plunger to drop the paste. To demonstrate the effectiveness of the system was tested on the pad size R0603, R0805, and R1206 to control the plunger to drop the solder paste to achieve the required size. The results showed that the

prototype could be used to support the process of soldering PCB connect SMD components to the printed circuit board. And the prototype has a relative error between 2% - 5%.

#### Acknowledgment

The authors would like to thank all member of Airlangga Strike Team Robotic and Instrumentation, Universitas Airlangga who have helped in the manufacture of the dispenser mechanism in this research.

#### DAFTAR PUSTAKA

- [1] H. Wang, M. Liserre, & F. Blaabjerg, "Toward reliable power electronics: Challenges design tools and opportunities," *IEEE Industrial Electronics Magazine*, no. 2, pp. 17–26, 2013.
- [2] C. H. Huang, "Continued Evolution of Automated Manufacturing-Cloud-Enabled Digital Manufacturing," *International Journal of Automation and Smart Technology*, vol. 5, no. 1, pp. 2–5, 2015.
- [3] S. Kumar, S. Mallik, N. Ekere, & J. Jung, "Stencil printing behavior of lead-free Sn-3Ag-0.5 Cu solder paste for wafer level bumping for sub-100  $\mu\text{m}$  size solder bumps," *Metals and Materials International*, vol. 19, no. 5, pp. 1083–1090, 2013.
- [4] T. N. Tsai, "Modeling and optimization of stencil printing operations: A comparison study," *Computers & Industrial Engineering*, vol. 54, no. 3, pp. 374–389, 2008.
- [5] K. Suganuma, S. Sakamoto, N. Kagami, D. Wakuda, K. S. Kim, & M. Nogi, "Low-temperature low-pressure die attach with hybrid silver particle paste," *Microelectronics Reliability*, vol. 52, no. 2, pp. 375–380, 2012.
- [6] —, "Low-temperature low-pressure die attach with hybrid silver particle paste," *Microelectronics Reliability*, vol. 52, no. 2, pp. 375–380, 2012.
- [7] T. Aoki, K. Toriyama, H. Mori, Y. Orii, J. W. Nah, S. Takahashi, & K. Inomata, "IMS (injection molded solder) technology with liquid photoresist for ultra fine pitch bumping," *International Symposium on Microelectronics*, vol. 2014, no. 1, pp. 713–000 717, 2014.
- [8] D. P. Prince, "Systems for detecting defects in printed solder paste," *Speedline Technologies Inc*, pp. 438–438, 2007.
- [9] Q. Zheng, M. A. Khan, A. M. Krizan, & G. H. Bernstein, "Electrical and mechanical performance of quilt packaging with solder paste by pin transfer," *Journal of Microelectronics and Electronic Packaging*, vol. 9, no. 4, pp. 160–165, 2012.

- [10] S. Gu, X. Jiao, J. Liu, Z. Yang, H. Jiang, & Q. Lv, 2016, *Micromachines*.
- [11] L. M. Fu, W. C. Fang, T. F. Hong, & C. Y. Lee, "A magnetic micropump based on ferrofluidic actuation," *International Journal of Automation and Smart Technology*, vol. 4, no. 2, pp. 77–82, 2014.
- [12] M. Berthou, P. Retailleau, H. Frémont, A. Guédon-Gracia, & C. Jéphos-Davennel, "Influence of PCB design and materials on chip solder joint reliability," *In 2010 11th International Thermal, Mechanical & Multi-Physics Simulation, and Experiments in Microelectronics and Microsystems (EuroSimE)*, pp. 1–6, 2010.
- [13] R. T. Yunardi & A. Imandiri, "Design of The 3D Surface Scanning System for Human Wrist Contour Using Laser Line Imaging," *2018 5th International Conference on Information Technology, Computer, and Electrical Engineering (ICITACEE)*, pp. 1–5, 2018.
- [14] S. V. Upadhyaya, D. Israni, K. Jasani, & A. Shah, "A novel approach to precisely control linear movement of sensor by motor using microstepping," *2016 IEEE Distributed Computing, VLSI, Electrical Circuits and Robotics (DISCOVER)*, pp. 242–246, 2016.

Conflict of Interest Statement: The author declares that the research was conducted in the absence of any commercial or financial relationships that could be construed as a potential conflict of interest.

Copyright © 2019 Author [s]. This is an open-access article distributed under the terms of the Creative Commons Attribution License (CC BY). The use, distribution or reproduction in other forums is permitted, provided the original author(s) and the copyright owner(s) are credited and that the original publication in this journal is cited, in accordance with accepted academic practice. No use, distribution or reproduction is permitted which does not comply with these terms.

Received: 2019-09-20

Accepted: 2019-10-25

LIST OF TABLES

I The results of the droplet size tests of paste ..... 6

TABEL I. THE RESULTS OF THE DROPLET SIZE TESTS OF PASTE

Pad Tipe	Pad L x W (mm)	Pad Size (mm <sup>2</sup> )	Test Result Size (mm <sup>2</sup> )		
			Max Size	Min Size	Ave Size
R0603	0.9x0.6	0.54	0.69	0.52	0.57
R0805	1.3x0.7	0.91	1.05	0.79	0.89
R1206	1.6x0.9	1.44	1.96	1.13	1.42

## LIST OF FIGURES

1	Design of solder paste dispenser .....	8
2	Illustration model of the solder paste dispenser.....	9
3	The flowchart of the operating mode for dispenser system.....	10
4	Electrical wiring diagram of main controller.....	11
5	Voltage step down, microcontroller and motor driver.....	12
6	Connection of LCD display and push buttons.....	13
7	Connection of LCD display and push buttons.....	14
8	The prototype of the solder paste dispenser.....	15
9	The prototype of the solder paste dispenser.....	16

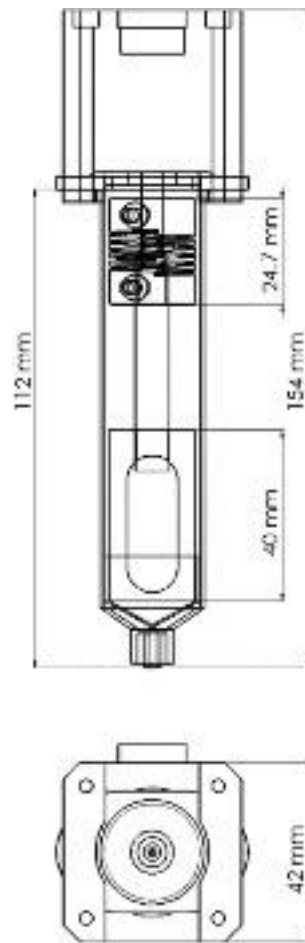

Gambar 1. Design of solder paste dispenser.





Gambar 2. Illustration model of the solder paste dispenser

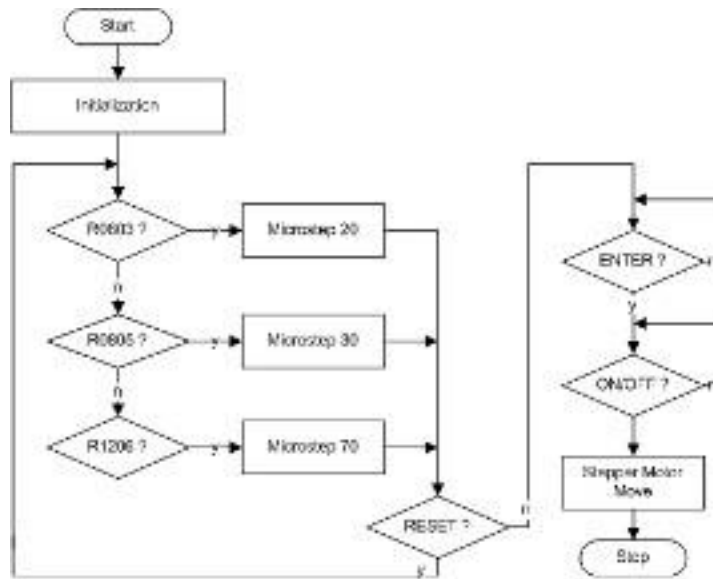

Gambar 3. The flowchart of the operating mode fordispenser system.

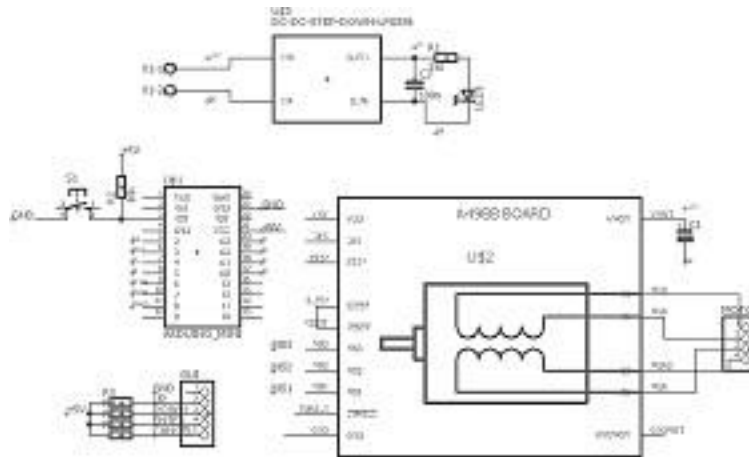

Gambar 4. Electrical wiring diagram of main controller.



Gambar 5. Voltage step down, microcontroller and motor driver.



Gambar 6. Connection of LCD display and push buttons.



Gambar 7. Connection of LCD display and push buttons.



Gambar 8. The prototype of the solder paste dispenser.



Gambar 9. The prototype of the solder paste dispenser.